

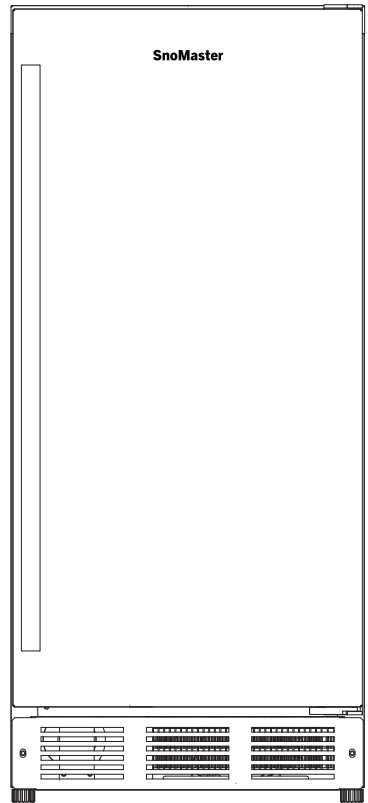

USER MANUAL AND PRODUCT SPECIFICATIONS

ICE COLD ANYWHERE

PLUMBED-IN ICE-MAKERS

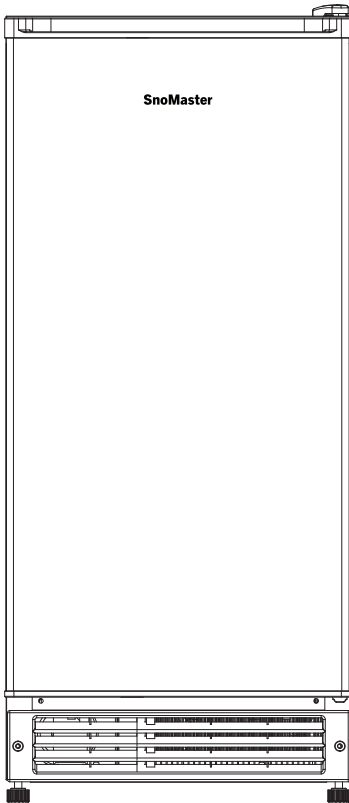

MODELS:
SMIC-25 | SMIC-30S

CONTENTS

WARRANTY, SERVICE AND SUPPORT	01
Warranty Registration	
Service and Support	
IMPORTANT SAFETY INFORMATION	02
Critical Safety Information	
Before Using Your Appliance	
PRODUCT FEATURES	04
OPERATION PROCEDURE	09
Installing The Appliance	
Reversing The Door	
Operating The Appliance	
Control Panel	
TROUBLESHOOTING	27



THAN YOU FOR PURCHASING YOUR SNOMASTER PLUMBED-IN ICE-MAKER

• WARRANTY, SERVICE AND SUPPORT •

This product is warranted for **2-years from the date of purchase**. Warranty does not cover products that have not been used in accordance with the user guide or are outside the warranty terms and conditions, which can be found at the following url:

<https://snomaster.co.za/warranty/>

WARRANTY REGISTRATION

Register your SnoMaster Plumbed-In Ice-Maker now for warranty, and allow us to provide you with the best possible after sales service:

- Please log onto our website at **www.snomaster.co.za**
- Click on the 'Warranty' tab.
- Enter warranty information and upload proof of purchase at the bottom of the page.

SERVICE AND SUPPORT

Should an instance arise where you require assistance, contact our service team:

- Please log onto our website at **www.snomaster.co.za**
- Click on the 'Support' tab.
- Click 'Find a Repair Agent Near You' and enter your region.
- Alternatively contact us via email: **info@snomaster.co.za** or contact us on **+27 11 392 5315**.

IMPORTANT SAFETY INFORMATION

SNOMASTER PLUMBED-IN ICE-MAKERS

This manual contains important information including safety, installation, maintenance and warranty instructions of your SnoMaster Plumbed-In Ice-Maker. Please read this manual carefully before use and follow all safety information and instructions. It is recommended to keep this manual for easy reference so that you are familiar with the operation and maintenance of your appliance.

CRITICAL SAFETY INFORMATION

Before using this appliance, ensure it is correctly positioned and installed as outlined in this manual. Follow these basic precautions to prevent the risk of fire, electrical shock, or injury:

- This appliance is designed for domestic indoor use only and is exclusively intended for making ice.
- Ensure that the incline angle of the appliance is not more than 45° during transportation or operation.
- Before using your appliance for the first time, you should wait about 12 hours after positioning it in a place.
- Ensure sufficient personnel are available to move and install the appliance to prevent damage or injuries.
- Installation of this appliance by a certified plumber is recommended.
- The appliance needs to be levelled for optimal operation. You can adjust the appliance feet to level it +/- 10mm.
- Ensure the plug is easily accessible after positioning the appliance.
- Avoid connecting or disconnecting the electric plug with wet hands.
- To disconnect the appliance, grip the plug and pull it from the wall outlet. Never pull out the plug by the cord.
- It is advisable to use a dedicated power source and avoid using extension cords.
- Please unplug the appliance or disconnect the power before performing any cleaning, maintenance, or servicing.

- If the appliance power supply cord is damaged, it must be replaced by SnoMaster, its approved agent, or a similarly qualified person to prevent any hazard.
 - It is recommended that the circuit breaker size of 15A.
 - This appliance operates on a single-phase voltage of 220VV/50Hz, to avoid electrical surges, it is advised to use a surge protector plug.
 - Cleaning and maintenance should be supervised by adults, especially if children are involved.
 - The appliance should be placed on a flat surface and should be completely unobstructed. Ensure to leave 150mm space around the appliance to ensure proper ventilation for the appliance. Place the appliance away from direct sunlight and heat sources (stove, heater, radiator, etc.).
 - Unless specifically recommended in this manual, do not attempt to repair or replace any part of the appliance. All other servicing should be referred to a qualified technician.
 - Never clean appliance parts with flammable fluids as they may create a fire hazard or explosion. Also, avoid storing or using petroleum or other flammable vapours and liquids near this appliance.
 - Avoid solvent-based cleaning detergents or abrasives on the interior or exterior as they may damage or discolour it.
-

BEFORE USING YOUR APPLIANCE

- Ensure all packaging materials, stickers and films are removed from the product. Clean the appliance's surfaces with a mild detergent and a damp cloth before initial use.
- Before connecting the appliance to a dedicated power source, let it stand upright for approximately 12 hours. This measure helps minimise the risk of cooling-system malfunctions that might occur due to handling during incorrect transportation.
- Ensure all electrical connections are clean and dry before switching on the appliance.
- Ensure all parts are correctly assembled before operation.



This appliance contains R290a refrigerant, which is **FLAMMABLE** and may cause a fire or an explosion.



WHEN DISPOSING THE APPLIANCE

Please observe the following instructions:

- Always ensure the appliance is out of reach of children.
- Before disposing of it, damage the body to prevent children from climbing inside, ensuring their safety.
- Follow your local regulations when disposing of the appliance.

SMIC-25

30KG/24HR PLUMBED-IN BULLET TYPE ICE-MAKER

PRODUCT FEATURES

ICE TYPE: BULLET ICE | SIZE (MM): (H) 30 (W) 38 | 28 ICE BULLETS PER CYCLE | 12KG ICE STORAGE BIN | INTERNAL LED CONTROL PANEL | ICE FULL SENSOR | WATER LOW SENSOR | INCLUDES: ICE SCOOP, 1 X WATER FILTER + 2 L TYPE QUICK CONNECTORS, WATER PIPE WITH QUICK FITTING & 1 DRAIN PIPE

SPECIFICATIONS:

- **Dimensions (mm) Unit:** (H) 864 (W) 378 (D) 573
 - **Dimensions (mm) Packaged:** (H) 895 (W) 420 (D) 654
 - **Storage Bin Volume:** 12Kg
 - **Net Weight:** 38Kg
 - **Ice Making Capacity:** 30Kg/24h
 - **Voltage:** 220V/50Hz
 - **Total Input Power:** 323W
 - **Rated Current:** 2A
 - **Suggested Applications:** Small Office, Apartment, Kitchen, B&B, Home Bar, Café , Cocktail Bar
 - **Design Criteria:** Designed for African conditions
-

SMIC-30S

30KG/24HR PLUMBED-IN GOURMET TYPE ICE-MAKER

PRODUCT FEATURES

ICE TYPE: GOURMET ICE | SIZE (MM): (H) 32(D) 32 | 24 GOURMET ICE PER CYCLE | 12KG ICE STORAGE BIN | INTERNAL LED CONTROL PANEL | ICE FULL SENSOR | WATER LOW SENSOR | INCLUDES: ICE SCOOP, 1 X WATER FILTER + 2 L TYPE QUICK CONNECTORS, WATER PIPE WITH QUICK FITTING & 1 DRAIN PIPE

SPECIFICATIONS:

- **Dimensions (mm) Unit:** (H) 852 (W) 378 (D) 573
 - **Dimensions (mm) Packaged:** (H) 895 (W) 420 (D) 654
 - **Storage Bin Volume:** 12Kg
 - **Net Weight:** 38.6Kg
 - **Ice Making Capacity:** 30Kg/24h
 - **Voltage:** 220V/50Hz
 - **Total Input Power:** 323W
 - **Rated Current:** 2A
 - **Suggested Applications:** Small Office, Apartment, Kitchen, B&B, Home Bar, Café , Cocktail Bar
 - **Design Criteria:** Designed for African conditions
-

**WATER INLET ~ WATER FILLING ~ ICE MAKING
~ WATER RELEASING ~ ICE DROPPING**

All these processes are automatically controlled for continuous ice-making.

Should the water supply deplete or the ice storage bin reach capacity, the operational panel's indicator light will activate, and the ice-maker will cease operation automatically. The insulated design of the ice storage bin serves to maintain the ice in a solid state for an extended period.

**Please Note: The ice storage bin is not refrigerated.*

INSTALLATION INSTRUCTIONS



Before installing your new appliance, please read all safety instructions in this manual and follow the installation instructions below:

WATER

- Water treated with reverse osmosis purification often gives a false water indicator, it is advised to fit an inline mineral filter for the sensors to detect the water.
 - Ice cycle time is dependent on water temperature. Clean and drain the appliance at least one or twice a month. Lemon juice or 10ml vinegar can be added to the water to help the cleaning process.
 - To prevent lime build-up it is advised to clean the appliance with a descaling liquid once a month, dependent on the water quality in your area.
-

ACCESSORIES INCLUDED

Please Check If All The Accessories Shown Below Are Included:



1 x ICE SCOOP

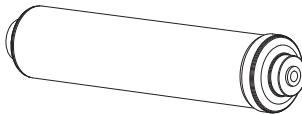

1 x FILTER CARTRIDGE

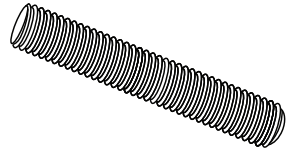

1 x DRAIN PIPE

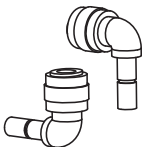

2 x L TYPE QUICK CONNECTORS

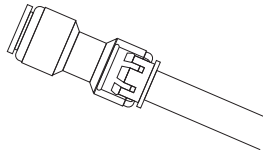

1 x WATER PIPE WITH QUICK FITTING

STRUCTURE

SMIC-25

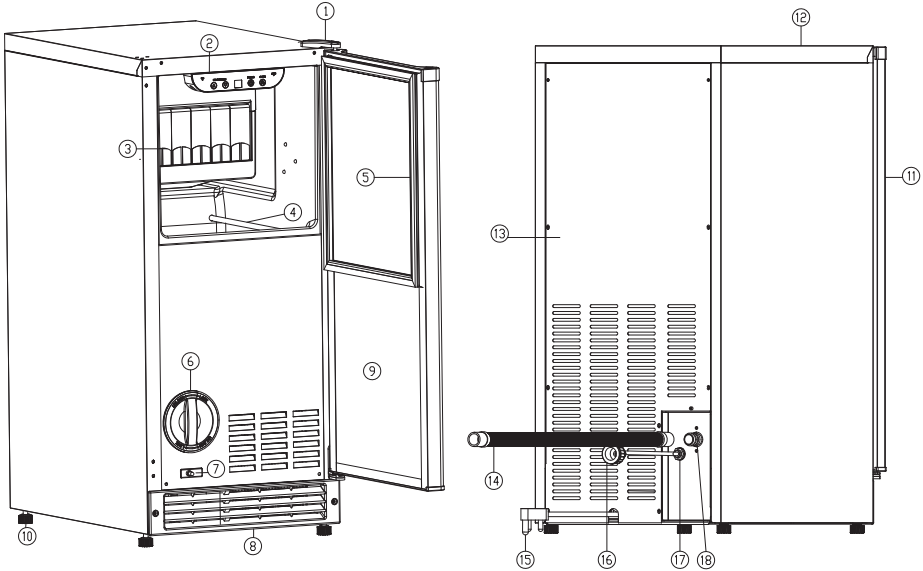

- 1** Top Hinge
- 2** LED Controller Panel
- 3** Water Curtain
- 4** Ice Full Sensor Tube
- 5** Door Gasket
- 6** Filter Cover
- 7** Light Switch
- 8** Kick Plate
- 9** Door Liner

- 10** Feet
- 11** Door
- 12** Top Panel
- 13** Back Panel
- 14** Drain Hose
- 15** Power Cord
- 16** Water Supply Pipe
- 17** Water Inlet Connector
- 18** Water Outlet Drain Connector

STRUCTURE

SMIC-30

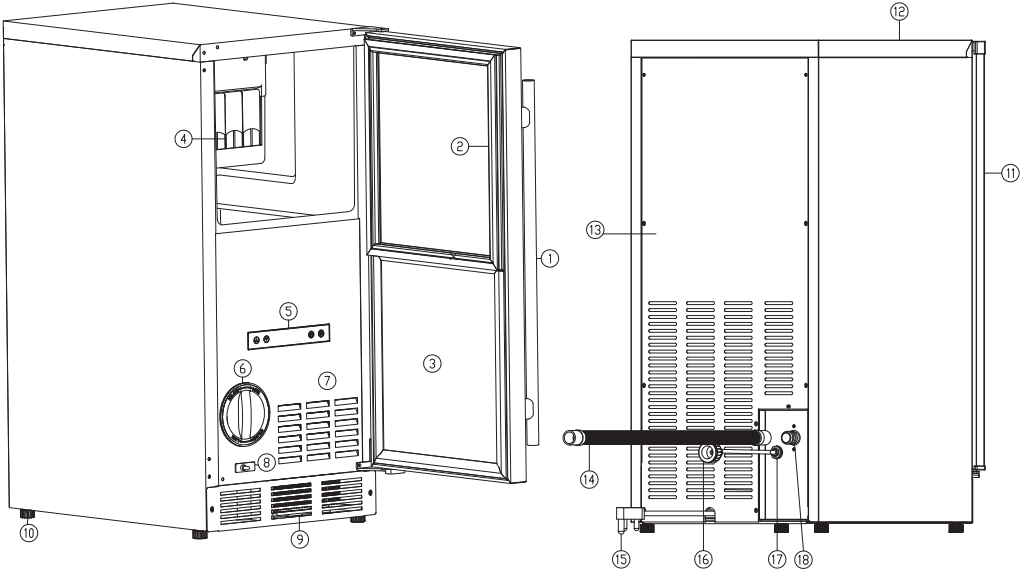

-
- | | |
|------------------------------|--|
| 1 Door Handle | 10 Feet |
| 2 Door Gasket | 11 Door |
| 3 Door Liner | 12 Top Panel |
| 4 Water Curtain | 13 Back Panel |
| 5 LED Control Panel | 14 Drain Hose |
| 6 Filter Cover | 15 Power Cord |
| 7 Cabinet Front Panel | 16 Water Supply Pipe |
| 8 Light Switch | 17 Water Inlet Connector |
| 9 Kick Plate | 18 Water Outlet Drain Connector |
-

SURGE PROTECTOR PLUG

To protect the appliance from electrical surges, it is advised to use a surge protector plug.

(Please note that this must be purchased separately and is not supplied with the appliance.)

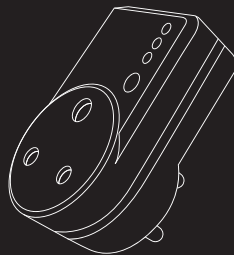

OPERATION PROCEDURE

Installation of this appliance by a certified plumber is recommended

- Remove the appliance from the box and all accessories.
- Ensure the appliance is placed on a level floor for quieter operation.
- Beware that placing the appliance on a carpet may cause the heat from the compressor to cause the carpet to fade.
- To maximize the ice-making performance of our plumbed-in ice-makers, it's ideal to have them in a steady environment with a 20°C ambient temperature and 10°C water temperature. While our ice-makers can handle higher temperatures, these conditions ensure peak production capacity.
- Avoid areas where the appliance might be exposed to direct sunlight, any sources of heat (stove, heater, radiator, etc.), extreme hot ambient temperatures or excessive moisture.
- Attach one end of the water inlet pipe to the water inlet valve on the back of the appliance. When connecting this pipe, use the sealing washers supplied with the ice-maker to eliminate the risk of a water leak.
- Connect the other end to a dedicated water supply or tap. When connecting this water inlet, use the sealing washers supplied to eliminate the risk of a water leak.

- Remove the protective plastic film from the filter cartridge prior to installation. Carefully align the cartridge within the filter housing, ensuring it is seated evenly within the designated grooves. Ensure the filter cover is tightened and secure before using the appliance.
- The drain outlet pipe must be fitted to the drain outlet fitting on the ice-maker. Use a cable tie to secure it once fitted to prevent leakage.
- The water pressure must be between 2 and 4 bar.
- Plug the power cord into a dedicated power source, then press the on/off switch to start the ice-making process. The green “run” light will be lit, and the ice-maker will start to operate.
- The operation of the ice-maker is completely automatic.
- If the 12Kg ice storage bin is full with ice, the “ice full” indicator on the display panel will be lit up, and the ice-maker will stop automatically.
- Remove the ice from the ice storage bin and then the ice-maker will restart automatically after a short while.
- Should the water supply to the appliance be insufficient, the “water low” light indicator will light up. The ice-maker will stop automatically.
- When the water supply is restored, the ice-maker will restart automatically again after a short while.



**INSTALLATION BY A CERTIFIED
PLUMBER IS RECOMMENDED**

INSTALLING THE APPLIANCE

- Using softened water may result in white, mushy cubes that stick together. Avoid using water.
- Using a RO system may cause the water pressure to be lower than the minimum the ice machine requires.
- Ensure that the water supply hose is not pinched, kinked, or damaged during installation.

RECESSED INSTALLATION

This ice machine can be installed under a counter or inside a kitchen cabinet, provided the required clearance is maintained around the unit. Ensure there is adequate space at the rear for water, drain, and electrical connections.

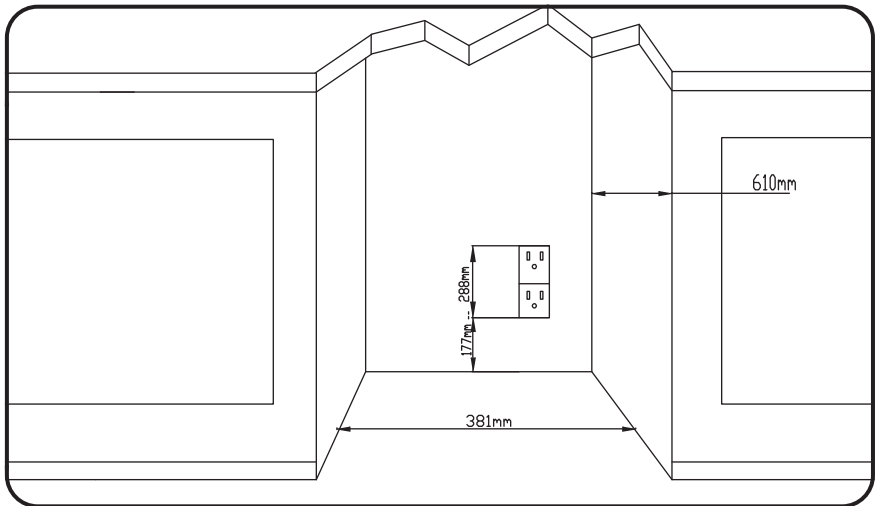

BUILT-IN CABINET DIMENSIONS

This unit is designed for built-in installation with zero clearance needed at the top and sides. However, you must allow sufficient space at the rear for the water line and power plug to ensure proper operation.

The appliance uses fan-assisted condenser cooling and requires air to circulate through the lower front section. Do not block or cover the front ventilation grill, as this may affect performance and prevent proper servicing. No additional ventilation is required at the top, sides, or rear of the unit.

NOTICE

- Ensure that the air path for the grille remains unrestricted. Any restriction of flair flow through the grille will disrupt normal operation of the unit, resulting in damage to components, and voids warranty.
- Connect the unit to a potable water supply only.

CONNECTING THE WATER SUPPLY

IMPORTANT: Improper water line connection may result in flooding. Professional installation is recommended. Ensure to contact a plumber to assist with installation.

- The ice maker requires a continuous water supply with a minimum pressure between 2 and 4 Bar.
- The temperature of the water feeding into the ice maker should be between 4°C and 32°C for proper operation.
- Deionized water is not recommended for use with this unit. Ensure that hoses are not damaged during installation and check for leaks after connecting the water line.

CONNECTING THE WATER LINE

1. Press the O-ring collect and Pull out the plug;
2. Insert the 6.35mm tube to the quick fitting;
3. Insert the locking clip to the quick fitting;
4. Connect the female adapter to faucet, open up and **CHECK FOR LEAKS.**

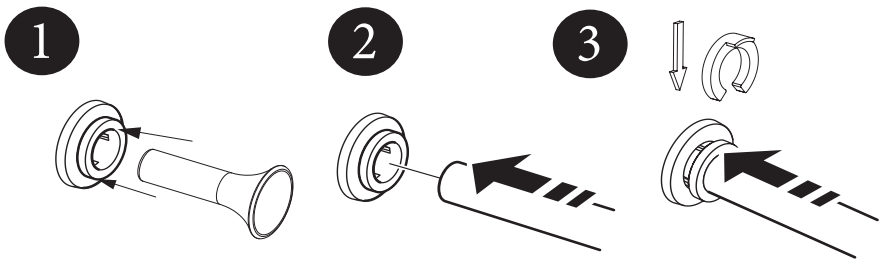

ELECTRICAL CONNECTION

Do not, under any circumstances, cut or remove the third (ground) prong from the power cord. For personal safety, you must properly ground this appliance. The power cord of this appliance features a three-prong grounding plug that mates with a standard three-prong grounding wall outlet to minimise the possibility of electric shock hazard from the appliance. Have a qualified electrician check the wall outlet and circuit to make sure the outlet is properly grounded. It is your responsibility and obligation to have a standard two-prong wall outlet replaced with a properly grounded three-prong wall outlet.

Always plug the appliance into its own individual electrical outlet. The voltage rating of the outlet must match the rating label on the appliance. This match provides the best performance and prevents overloading the electrical circuits, which could cause a fire hazard from overheated wires.

**Never unplug your appliance by pulling on the power cord.
Always grip the plug firmly and pull straight out from the outlet.**

Repair or replace all power cords immediately that have become frayed or damaged. Do not use a cord that shows cracks or abrasion damage along its length or at either end. When moving the appliance, take care not to damage the power cord. If the power supply cord is damaged, have the manufacturer, its service agent, or similarly qualified persons replace the supply cord to avoid a hazard.

DRAIN PUMP TEST

- 1. Check the power cord and make sure it is not plugged into the outlet.**
- 2. Place the drain hose into a suitable container that can hold at least five litres of water.**
- 3. Pour five litres of water into the ice storage bin.**
- 4. Plug the power cord into a properly grounded, polarised electrical outlet.**
- 5. The drain pump should start and pump the water from storage bin into the container. Continue until bin empties.**
- 6. If water does not drain check power supply, confirm nothing is blocking water from drain.**
- 7. Once water empties unplug the power cord and complete installation.**

CONNECTING DRAIN

- With Factory installed drain pump proper connection to drain is required.
 - It is recommended that a proper drain system include an air gap to prevent siphoning and a sanitary trap (Check local codes to determine drain requirements).
 - Improper drain can lead to malfunctions in the ice production and void warranty.
 - Licensed Plumbers can assist in identifying proper drain hook up.
-

FILTER INSTALLATION/REPLACEMENT

The filter must be installed in accordance with the manufacturer's recommended procedures and guidelines. To reduce the risk associated with property damage due to water leakage, you must read and following installation and use instructions before installation and use this product. For replacement, contact your local agent or the SnoMaster service centre.

NOTICE

- 1. Always disconnect power and water at the source before working on the appliance.**
- 2. The filter must be replaced every 6 months, at the rated capacity or if a noticeable reduction in flow occurs.**
- 3. Before installation or replacement, always use the water pipe to connect the filter to the water supply separately first, and then run water for at least 5 minutes to purge the filter until the water is clear.**
- 4. Insert the tube to the end of the built-in quick-connectors, and always check for leaks before fixing.**



AVOIDING USE OF EXTENSION CORDS

Because of potential safety hazards under certain conditions, avoid using an extension cord with this appliance.

FILTER INSTALLATION/REPLACEMENT

1. Rotate the water filter cover 90 degrees counterclockwise. Remove the cover to expose the filter connecting tubes of the ice machine.
2. The water tubes are being connected by a joint connector so the ice machine CAN work without a filter. Take away the two clips on both ends of the joint connector, pull the tube out from it, **PAY ATTENTION TO THE LABEL ON THE TUBES.**

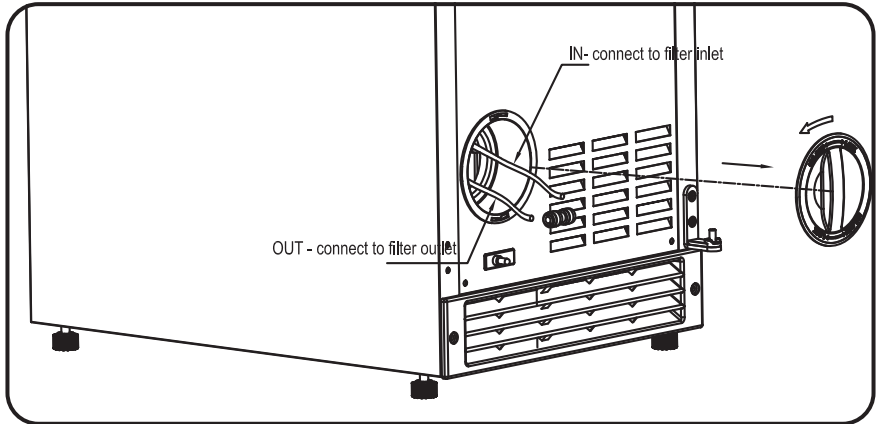

3. Assembly the two L type quick connectors and insert to the thick end of the filter, this is the water inlet end.
4. BEWARE THE FLOW DIRECTION ARROW OF THE FILTER, Insert the filter connecting tubes to the filter's quick connectors on both ends, until the tube reaches the bottom (approx 1/2"). Then turn on the water supply to check for leaks.

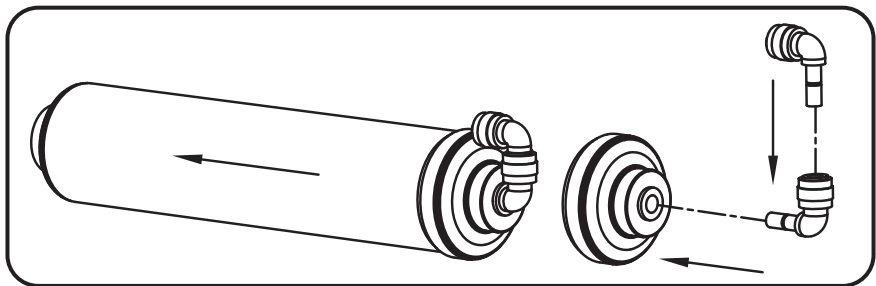

5. If there are no leaks, put the filter into the filter cave, and Install the water filter cover by rotating the cover 90 degrees clockwise.

LEVELING THE UNIT

Place your ice machine on a level surface that is strong enough to support the ice maker when it is fully loaded. Level your ice maker by adjusting the legs at the front of the ice machine. If necessary, raise or lower the unit by turning the four leveling feet at the bottom.

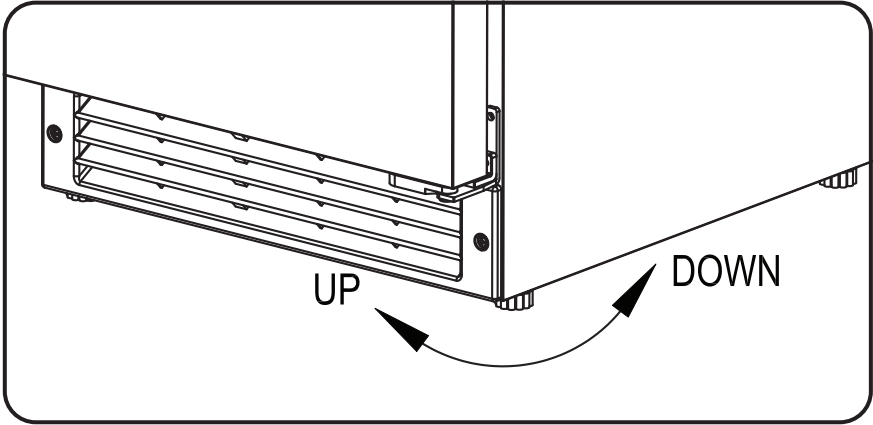

REVERSING THE DOOR (UNIT - SMIC-30)

Place your ice machine on a level surface that is strong enough to support the ice maker when it is fully loaded. Level your ice maker by adjusting the legs at the front of the ice machine. If necessary, raise or lower the unit by turning the four leveling feet on the bottom.

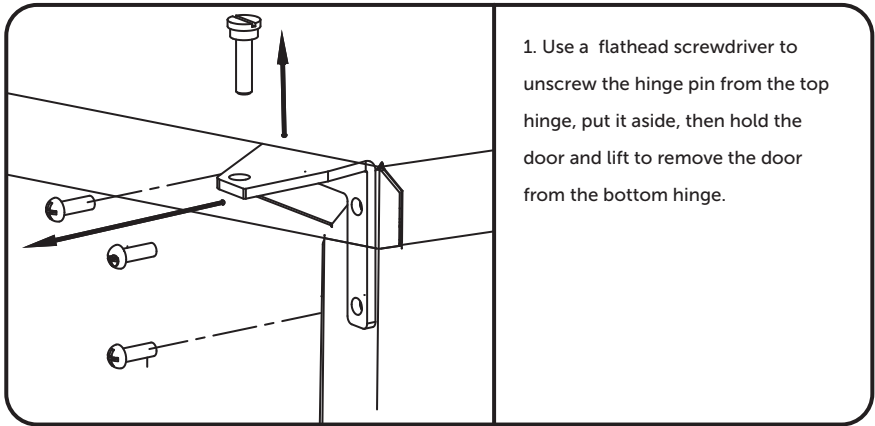

1. Use a flathead screwdriver to unscrew the hinge pin from the top hinge, put it aside, then hold the door and lift to remove the door from the bottom hinge.

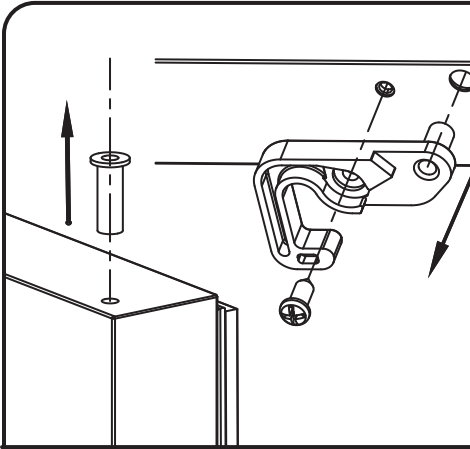

2. The door will rotate 180° to reverse swing. First unscrew to remove the right latch hook from the bottom of the door and take out the pin sleeve from the top of the door. Then swap the sleeve pin location to the bottom of the door, find the left latch hook in the accessory bag and install it to the other side of the door.

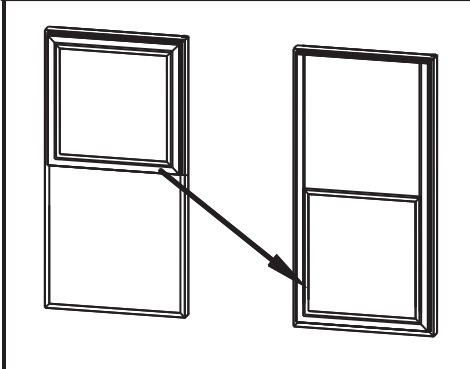

3. Carefully peel off the whole door gasket from any of the corners and remove the inserts in the other side of the door liner from the mounting groove, then swap their location, install the door gasket to the opposite side of the door and push the insert to the exposed mounting grooves. Now the door gasket has been reinstalled.

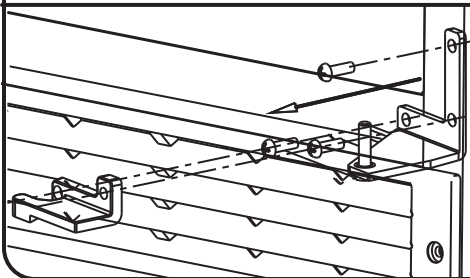

4. Use a Phillips screwdriver to unscrew the screws fixing the top and bottom hinges to uninstall them both. Take out the right latch block on the bottom hinge, keep the removed right latch kit for future use.

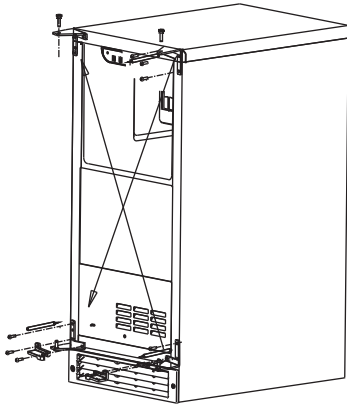

5. Cross swap the hinge locations, install the bottom right hinge to the left top of the cabinet and the top right hinge to the left bottom of the cabinet. Cover the right mounting holes by the plugs just disassembled from the left.

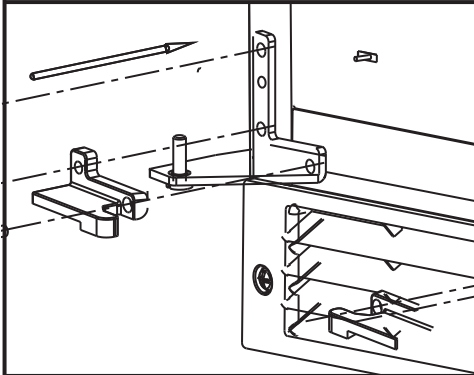

6. When installing the left bottom hinge, find the left latch block in the accessory bag, and install it with the bottom hinge. Also unscrew the hinge pin from the left top hinge for door installation.

7. Align the left latch block to the bottom hinge pin, insert the door. Align the pin sleeve on the top of the door to the top hinge and install the hinge pin, tighten firmly. The door reversing is complete.

REVERSING THE DOOR - SMIC-25

This appliance has the capability of the door opening from either the left or right side. The appliance is delivered to you with the door opening from the left side. Follow these instructions should you desire to reverse the opening direction.

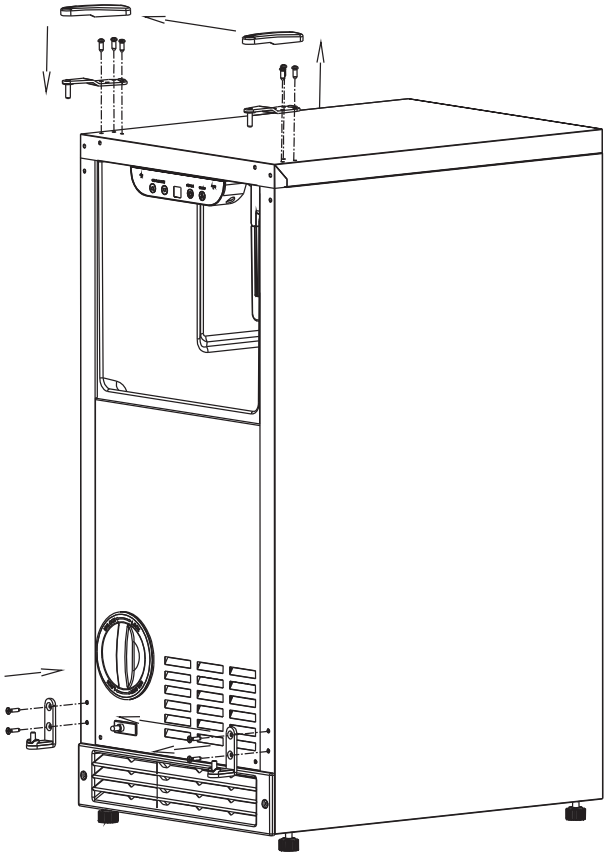

1. Open the hinge cap on the top hinge and unscrew the three (3) bolts to take away the top hinge and then lift out the door.
2. Cover the left screw holes by the decorative plugs from the right.
3. Pull off the front louver vents, get access to the bottom hinge, uninstall it and reinstall on the left side of the cabinet, then recover the front louver vents.
4. Align the door to the bottom hinge and insert the door, then install the top hinge cap and put the hinge cap on it.

OPERATING THE APPLIANCE

IMPORTANT: ENSURING ICE FRESHNESS AND QUALITY

- Although the unit has been tested and cleaned at the factory, discard the first batch of ice cubes due to long-term transit and storage.
- If you do not use the ice machine regularly, the manufacturer recommends emptying the ice bin periodically to ensure ice freshness.
- The ice machine produces ice in layers resulting in a clear cube. The ice may appear wet when first produced. Ice in the bin may develop surface frost which appears when the cube is placed in liquid.

OTHER OPERATING TIPS

- Keep the air intake and exhaust free of dust and lint to allow free air flow. With hard water, cleaning may have to be more frequent.
- Never touch the evaporator when the unit is running.
- Keep the door closed to reduce ice melting and to promote proper ice formation. Open the door only when taking ice from the appliance.
- Turn on the water supply tap before switching on the ice machine. Never turn the water supply tap off when the ice machine is working.

ICE MACHINE PRODUCTION





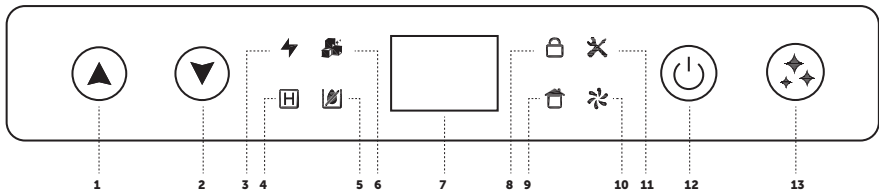

















The gourmet ice machine (SMIC-30S) produces 24 individual ice cubes per cycle. The bullet ice machine (SMIC-25) produces 28 individual ice bullets per cycle. The ice machine will continue to produce ice until the ice in the bin contacts the ice full indicator in the bin. Once the ice level drops below the indicator, the ice machine will begin producing ice again.









SMIC-30S LED CONTROL PANEL



1 Up	4 Timed Start	7 Display Window	10 Clean Indicator	13 Clean Button
2 Down	5 Low Water	8 Screen Lock	11 Maintenance Indicator	
3 Fast Ice Making	6 Ice Making	9 Showroom	12 Power Button	

The control panel is located at the top of the cabinet and includes a display window, 4 buttons and 8 indicators.

FUNCTION		OPERATING
Turn On		<p>Press "  " to turn ON the unit The unit will automatically start making ice and display "ICE" on ice making, "HAE" on ice harvesting, "FUL" on ice full, and "FUO" on Ice making recovery countdown. The Ice making indicator will light up during the ice making cycle.</p>
Turn Off		<p>Press and hold "  " for 3 seconds to immediately turn OFF the unit.</p> <p>The unit will standby and display "OFF" . If ice making has already started, the unit will complete the current cycle before entering standby mode.</p> <p>*If the unit is producing ice, it may leave a batch of incomplete ice cubes in the bin.</p>
Adjust the ice cube size	 	<p>Press and hold the "  " or "  " button for at least 3 seconds to enter the ICE SIZE ADJUSTING mode. Use the "  " or "  " button to change the settings.</p> <p>The window will display "1" to "9" (min to max). 5 is the default ice size. The setting will be saved after 7 seconds.</p>
Fast Ice Making	 	<p>Press and hold both the "  " and "  " buttons for more than 3 seconds to toggle Fast Ice Making ON/OFF.</p> <p>The fast ice making indicator will illuminate, indicating that the ice making cycle is now shorter.</p>
Timed Ice making	 	<p>Press and hold the "  " and "  " buttons for at least 3 seconds while in Standby mode to toggle Timed Ice Making ON or OFF. When entering the timer setting, press "  " or "  " to select a duration from "1" to "12" hours for the ice making cycle. This setting will auto save after 10 seconds, then the window display will show the countdown in hours while the timed ice making indicator lights up.</p> <p>*Pressing "  " will turn OFF the unit or place it in standby mode. Press the "  " again to start the ice making process again.</p>

FUNCTION		OPERATING
Cleaning		<p>Press and hold the " ✨ " for more than 3 seconds to turn ON/OFF the CLEANING function.</p> <p>Upon starting, the display will show CLE and the clean indicator will illuminate. The cleaning cycle will operate for 30 minutes before returning to standby mode.</p> <p>*This function can only start on standby mode.</p>
Sabbath	 	<p>Press and hold both the " ▲ " and " ✨ " for more than 6 seconds to turn ON/OFF the SABBATH mode.</p> <p>In SABBATH mode, the display, interior light, and all audible sounds will be disabled.</p>
Showroom	 	<p>Press and hold both the " ▼ " and " ✨ " for more than 6 seconds during standby mode to toggle ON/OFF the SHOWROOM mode.</p> <p>The SHOWROOM indicator will light up.</p> <p>*This mode is intended for dealer display purposes. Only the light and display panel will function, while all alarms will be disabled except for the door open alarm.</p>
Screen Lock	 	<p>Press and hold both the " ⏻ " and " ✨ " for more than 6 seconds to toggle ON/OFF the screen lock.</p> <p>The Screen lock indicator will illuminate and the screen will be locked.</p>
Firmware Version & System Recovery	 	<p>Press and hold " ⏻ " to turn OFF or place unit in standby mode.</p> <p>Press and hold both the DOWN and POWER buttons to display the firmware version (A5). Holding for more than 6 seconds will reset all settings to their default values.</p> <p>*The firmware version is subject to change.</p>



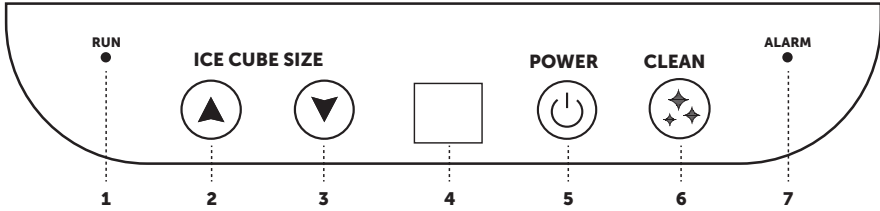







SMIC-25 LED CONTROL PANEL



- | | | | |
|------------------------|-------------------------|----------------|--------------------------|
| 1 Run Indicator | 3 Down | 5 Power | 7 Alarm Indicator |
| 2 Up | 4 Display Window | 6 Clean | |

The control panel is located at the top of the cabinet and includes a display window, 4 buttons and 8 indicators.

FUNCTION		OPERATING
Turn ON		Press the " " button to turn ON the unit. The unit will automatically start making ice and display "IC" during ice making and "FU" when the ice bin is full. The RUN indicator light will illuminate.
Turn Off		Press the POWER button to turn OFF the unit. This unit will enter Standby mode and display "OF" . *If the unit is already in the process of making ice, it will complete the current cycle before entering Standby mode. Press and hold the " " button for over 3 seconds to turn OFF the unit. *Incomplete ice cubes may remain in the bin if the unit is turned off while making ice.
Adjust the ice cube size	 	Press and hold the " " or " " button for over 3 seconds to enter ICE SIZE ADJUSTING mode. Then use the " " or " " button to change the settings. Window displays "1" to "9" (min to max). "5" is the default ice size. The setting will be saved after 5 seconds.
Cleaning		Press and hold the " " button for over 3 seconds to turn ON/OFF the CLEANING mode. Once cleaning begins, the window will display "CL", and the cleaning cycle will run for 30 minutes before exiting and then entering Standby mode. *This function can only be initiated in Standby mode.

FUNCTION		OPERATING
Timed Ice making	 	<p>Press and hold the "⏻" and "❄️" buttons for over 3 seconds during Standby mode to toggle ON/OFF the Timed Ice Making mode.</p> <p>When entering the time setting, press the "▲" or "▼" button to select a timer duration from "1" to "12" hours for the ice-making cycle. The setting will automatically save after 10 seconds, and the display will show the remaining countdown time in hours.</p> <p>*Pressing the POWER button will skip the countdown and immediately begin the ice-making process.</p>
Sabbath	 	<p>Press and hold the "▲" and "❄️" buttons for over 6 seconds to toggle Sabbath mode ON/OFF. IN SABBATH mode, the display will turn off, and audible sounds will be disabled.</p>
Showroom	 	<p>Press and hold both the "▼" and "❄️" buttons for more than 6 seconds during standby mode to toggle ON/OFF the SHOWROOM mode. The SHOWROOM indicator will light up.</p> <p>*This mode is intended for dealer display purposes. Only the light and display panel will function, while all alarms will be disabled except for the door open alarm.</p>
Filter Reset	 	<p>Press and hold the "▲" and "⏻" buttons for over 6 seconds to reset the water filter. The display window will flash "FO" and reset the filter timer.</p> <p>*This function can only be initiated on Standby mode. Use only after replacing the water filter.</p>
Firmware Version & System Recovery	 	<p>Press and hold "⏻" to turn OFF or place unit in standby mode.</p> <p>Press and hold the "▼" and "⏻" buttons to display firmware version A3. Holding these buttons for OVER 6 seconds will reset all settings back to default.</p> <p>*The firmware version is subject to change.</p>

OPERATING THE APPLIANCE

Your new ice machine may make sounds that are not familiar to you. Hard surfaces like the floor and walls can make the sounds seem louder than they actually are. The following are sounds and descriptions should you need to troubleshoot:

- The high-efficiency compressor may make a pulsating or high-pitched sound.
- Water running from the evaporator to the water reservoir may make a splashing sound.
- As each cycle ends, you may hear a gurgling sound due to the refrigerant flowing in your ice machine.
- Rattling noises may come from the flow of the refrigerant, the water line or items stored on top of the machine.
- You may hear the sound of the condenser fan forcing air over the condenser.
- During the harvest cycle, you may hear the sound of ice cubes falling into the ice bin.

PANEL DISPLAY NOTIFICATION

The following notifications will trigger an alarm (except for the "Ice Full Stop" notification).

	SMIC-30S	SMIC-25	
Self-Diagnosis Pass	888	88	Only displays at the start of the operating process.
Ice Full Stop	FUL	BF	<ul style="list-style-type: none"> • If the ice storage bin is full, the unit will automatically stop. • Remove the ice and the unit will start making ice after 3 minutes.
Ice Full Stop	dr	dr	If the door is not closed completely for 5 minutes, the panel will flash dr with alarm sounds. All alerts will be cleared when the door is closed or when any button is pressed.
Clean Reminder	CLE	CL	<ul style="list-style-type: none"> • After approximately 6 months of operation without running the CLEANING program, the panel will flash CLE / CLE as a reminder. • Run the CLEANING cycle to clear the alarm.

	SMIC-30S	SMIC-25	
Filter Replace Reminder	F11	F1	After approximately 6 months of operation, the panel will flash FIT as a reminder. Replace the filter and reset the filter timer to clear the alarm.

DEALING WITH POWER FAILURE

Most power outages are resolved within a few hours and typically do not affect the ice machine's temperature, provided the door remains closed as much as possible. If the power outage is expected to last longer, follow the appropriate procedure to disconnect the appliance.

Note: During operation, only the evaporator is cooled to produce ice. In the event of a power outage, the ice-making process will be interrupted, but the ice stored in the bin will melt gradually as usual.

FAULT ALARM AND ERROR CODES

When an error is detected, the unit will trigger an alarm, the ALARM indicator will flash, and the corresponding error code below will be displayed. Please provide the displayed error codes when contacting customer service.

FAULT ALARM	ERROR CODES	
	SMIC-30S	SMIC-25
Evaporator temperature sensor failure	E1	E1
Condenser temperature sensor failure	E2	E2
ICE FULL temperature sensor failure	E3	E3
Long harvest alarm	E4	E4
Low water alarm	E5	E5
Drain pump failure	PUE	PU
High ambient temperature	HIG	HI

The ice machine will keep running on E1, E2 error with the RUN indicator flashing and will completely stop working on the rest of the errors. Check "troubleshooting" for easy self diagnosis to try clearing error codes.

TROUBLESHOOTING

PROBLEM	POSSIBLE CAUSES	SOLUTIONS
The machine won't operate.	<ul style="list-style-type: none"> • The ice machine is unplugged. • The ice machine power switch is OFF. • The ice storage bin is full of ice. 	<ul style="list-style-type: none"> • Plug the ice machine in. • Verify that the control unit is properly programmed. • Remove some of the ice.
The compressor is operating abnormally and producing a buzzing noise.	The voltage is lower than recommended.	Stop the ice machine and do not restart until the voltage is normal.
The water does not flow into the machine after startup. (Possible error codes: E4/E5)	<ul style="list-style-type: none"> • The water supply tap is turned off. • The water supply pipe is not properly connected. • The water filter is not installed or not installed correctly. • Water inlet valve malfunction. 	<ul style="list-style-type: none"> • Turn on the water supply tap. • Reconnect the water supply pipe. • Check that the water filter is installed correctly. • Contact SnoMaster Service.
Machine makes ice, but at a very slow rate. (possible error codes HI/HIG).	<ul style="list-style-type: none"> • The condenser may be dirty. • The air flow to the ice machine may be obstructed. • The ambient temperature and water temperature are high, or the unit is positioned near a heat source. 	<ul style="list-style-type: none"> • Clean the condenser. • Check the installation to ensure the air flow to the ice maker is not blocked. • Check the installation to ensure the ambient temperature is in the proper range.
Water is leaking out of the unit. (Possible error codes: E4/E5)	<ul style="list-style-type: none"> • A few water droplets are on the door. • The water supply connection is leaking. • Incorrect filter installation. 	<ul style="list-style-type: none"> • Under certain conditions, humidity may condense on the door. To reduce condensation, consider relocating the unit or minimizing the frequency of door openings. • Tighten water supply hose-fitting • Check that the water filter is installed correctly.
Ice cubes are partially formed and appear white at the bottom. (Possible error codes: E4/E5)	There is not enough water in the water bin.	<ul style="list-style-type: none"> • Check if the water supply pressure is below 2 Bar. • Check the water supply. It may be restricted. • Check for a water leak at the water trough.
Noise during operation.	<ul style="list-style-type: none"> • The feet are not leveled. • Certain sounds are normal. 	<ul style="list-style-type: none"> • Level the feet. See "LEVELING THE UNIT". • See "EXPECTING NORMAL SOUNDS".

TROUBLESHOOTING

PROBLEM	POSSIBLE CAUSES	SOLUTIONS
<p>The ice made is too large and has pieces sticking together.</p>	<p>The water temperature in the storage tray or the ambient temperature is too low.</p>	<ul style="list-style-type: none"> • Stop the machine and reset the ice-making cycle. • Restart the machine after turning it off.
<p>Ice-making conditions are correct, but no ice is being produced.</p>	<ul style="list-style-type: none"> • The refrigerant leaks and/or the sealed system is blocked. • Water pressure is not properly set. 	<ul style="list-style-type: none"> • Contact SnoMaster Service. • The recommended water pressure is 2 to 4 Bar. Pressures must not fall below 2 Bar and static pressure must not exceed 4 Bar.
<p>The ice machine stops unexpectedly during the ice-making process.</p>	<ul style="list-style-type: none"> • The electricity is off. • The room temperature is out of the stated range. 	<ul style="list-style-type: none"> • Reconnect the power supply line. • Disconnect the power and allow the ice machine to remain off until the temperature returns to the specified range.
<p>The body of the ice machine is electrified.</p>	<p>The grounding line is not properly connected to the socket.</p>	<p>Use the correct plug and outlet.</p>
<p>Mineral scale accumulates rapidly inside the machine.</p>	<p>The calcium level in the water is too high.</p>	<p>Install a water softener at the water inlet valve to reduce mineral buildup.</p>



ICE COLD ANYWHERE

**JOHANNESBURG LIFESTYLE
CENTRE & SERVICE CENTRE**

49 Koornhof Road
Meadowdale
Germiston, 1614
011 392 5315 / 3147
info@snomaster.co.za

**CAPE TOWN LIFESTYLE CENTRE
& SERVICE CENTRE**

31 Stella Road
Montague Gardens
Cape Town, 7441
021 100 5695
info@snomaster.co.za

snomaster.co.za



@SnoMasterSA



SnoMaster SA



snomaster_south_africa



@SnoMaster