

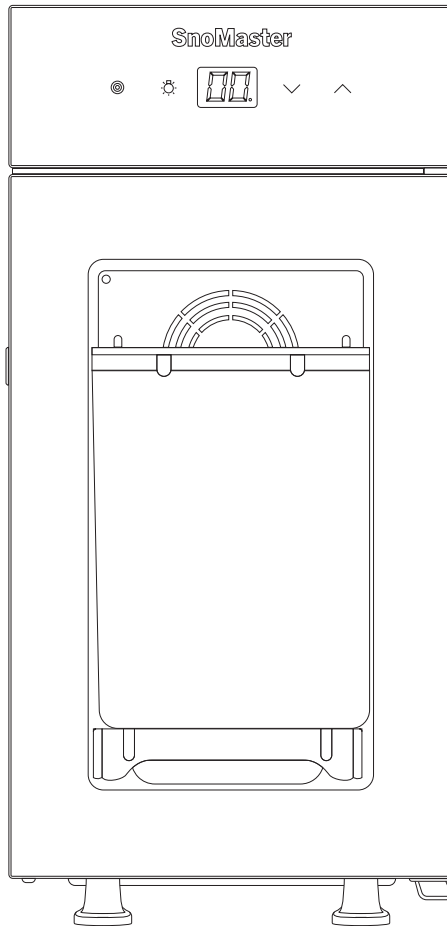

USER MANUAL AND PRODUCT SPECIFICATIONS

ICE COLD ANYWHERE



SMBC-2 COUNTER-TOP
MILK COOLER

CONTENTS

WARRANTY, SERVICE AND SUPPORT	01
Warranty Registration	
Service and Support	
IMPORTANT SAFETY INFORMATION	02
Critical Safety Information	
Disposing of the Appliance	
PRODUCT FEATURES	04
Installation Instructions	
Accessories	
Structure	
Control Panel	
Operation Procedure	
CLEANING THE APPLIANCE	06
Cleaning the Interior	
Cleaning the Exterior	
FOOD STORAGE	07
ENERGY SAVING TIPS	07
TROUBLESHOOTING	08



THANK YOU FOR PURCHASING THE SNOMASTER SMBC-2, 4.5L COUNTER-TOP MILK COOLER

• WARRANTY, SERVICE AND SUPPORT •

This product is warranted for **2 years from the date of purchase**. Warranty does not cover products that have not been used in accordance with the user guide or are outside the warranty terms and conditions, which can be found at the following url:

<https://snomaster.co.za/warranty/>

WARRANTY REGISTRATION

Register your SnoMaster SMBC-2, 4.5L Counter-Top Milk Cooler now for warranty, and allow us to provide you with the best possible after sales service:

- Please log onto our website at **www.snomaster.co.za**
- Click on the 'Warranty' tab.
- Enter warranty information and upload proof of purchase at the bottom of the page.

SERVICE AND SUPPORT

Should an instance arrive where you require assistance, contact our service team:

- Please log onto our website at **www.snomaster.co.za**
- Click on the 'Support' tab.
- Click 'Find a Repair Agent Near You' and enter your region.
- Alternatively contact us via email: **info@snomaster.co.za** or contact us on **+27 11 392 5315**.

IMPORTANT SAFETY INFORMATION

SNOMASTER SMBC-2, 4.5L COUNTER-TOP MILK COOLER

This manual contains important information including safety, installation, maintenance and warranty instructions of the SnoMaster SMBC-2, 4.5L Counter-Top Milk Cooler.

Please read this manual carefully before use and follow all safety information and instructions. It is recommended to keep this manual for easy reference so that you are familiar with the operation and maintenance of your appliance.

CRITICAL SAFETY INFORMATION

Before using this appliance, ensure it is correctly positioned and installed as outlined in this manual. Follow these basic precautions to prevent the risk of fire, electrical shock, or injury:

- This appliance is designed for domestic indoor use only and is exclusively intended for the storage of beverages and food stuffs.
- Ensure that the incline angle of the appliance is not more than 45° during transportation or operation.
- Before using your appliance for the first time, you should wait about 12 hours after positioning it in a place.
- The appliance needs to be levelled for optimal operation. You can adjust the appliance feet to level it +/- 10mm.
- Ensure the plug is easily accessible after positioning the appliance.
- Avoid connecting or disconnecting the electric plug with wet hands.
- To disconnect the appliance, grip the plug and pull it from the wall outlet. Never pull out the plug by the cord.
- It is advisable to use a dedicated power source and avoid using extension cords.
- Please unplug the appliance or disconnect the power before performing any cleaning, maintenance, or servicing.

- If the appliance power supply cord is damaged, it must be replaced by SnoMaster, its approved agent, or a similarly qualified person to prevent any hazard.
- It is recommended that the circuit breaker size should be no more than 20 amps.
- This appliance operates on a single-phase voltage of 230V/50Hz, to avoid electrical surges, it is advised to use a surge protector plug.
- Cleaning and maintenance should be supervised by adults, especially if children are involved.
- The appliance should be placed on a flat surface and should be completely unobstructed. Ensure to leave 150mm space around the appliance to ensure proper ventilation for the appliance. Place the appliance away from direct sunlight and heat sources (stove, heater, radiator, etc.).
- Unless specifically recommended in this manual, do not attempt to repair or replace any part of the appliance. All other servicing should be referred to a qualified technician.
- Never clean appliance parts with flammable fluids as they may create a fire hazard or explosion. Also, avoid storing or using petroleum or other flammable vapours and liquids near this appliance.
- Avoid solvent-based cleaning detergents or abrasives on the interior or exterior as they may damage or discolour it.



This appliance contains CYCLOPENTANE and R600a refrigerant , which is FLAMMABLE and may cause a fire or an explosion.



WHEN DISPOSING OF THE APPLIANCE

- Detach the door gasket and unlock the door to keep the door from being tightly closed.
- Always ensure the appliance is out of reach of children. Before disposing of it, damage the body to prevent children from climbing inside, ensuring their safety.

Follow the instructions of your local regulations when disposing of this appliance.

PRODUCT FEATURES

TEMPERED GLASS DOOR (RIGHT HINGED ONLY) | EXTERNAL LED TOUCH DISPLAY | INTERNAL LED LIGHT | INTEGRATED PLASTIC MILK CONNECTOR | INCLUDES: 4.5L PLASTIC MILK CONTAINER

SPECIFICATIONS:

- **Dimensions (mm) Unit:** (H) 455 (W) 230 (D) 450
 - **Dimensions (mm) Packaged:** (H) 530 (W) 290 (D) 530
 - **Net Weight:** 13.5Kg
 - **Storage Volume:** 4.5L
 - **Temperature Range:** -1°C - 5°C
 - **Voltage:** 230V/50Hz
 - **Total Input Power:** 60W
 - **Rated Current:** 0.5A
 - **Refrigerant:** R600a
 - **Foaming Agent:** Cyclopentane
 - **Suggested Applications:** Office, Apartment, Kitchen, B&B, Home Bar, Coffee Shop, Conference Venue
 - **Design Criteria:** Engineered for the African Climate
-

INSTALLATION INSTRUCTIONS



Before installing your new appliance, please read all safety instructions in this manual and follow the installation instructions below:

- Remove the appliance from the box, ensure all packaging materials, stickers and films are removed from the product. Clean the appliance's surfaces with a mild detergent and a damp cloth before initial use.
- Clean the interior, shelving and glass door with a mild detergent and damp cloth before initial use.
- Ensure the appliance is placed on a level, sturdy surface.
- **Caution:** Installing the appliance on carpeting may lead to discolouration due to heat emission from the compressor.
- Ensure adequate air circulation for the appliance by maintaining a clearance of at least 150mm on all sides.

ACCESSORIES INCLUDED



1 x 4.5L Plastic Milk Container

STRUCTURE

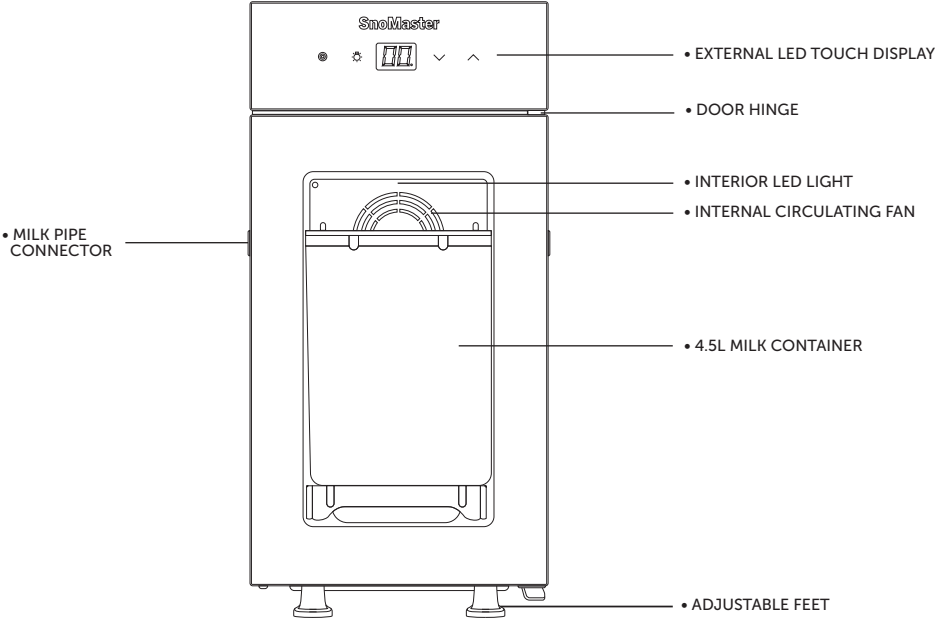

SURGE PROTECTOR PLUG



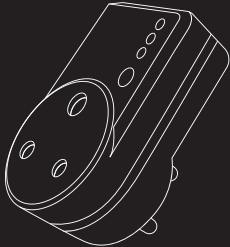

TO AVOID ELECTRICAL SURGES, IT IS ADVISED TO USE A SURGE PROTECTOR PLUG.

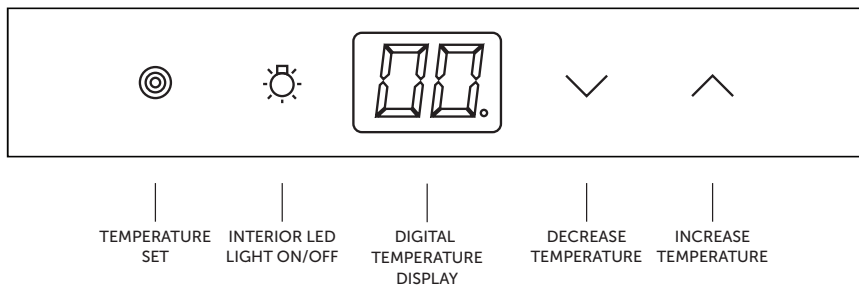

CONTROL PANEL



OPERATION PROCEDURE

- Connect the appliance to a dedicated power source.
- To increase or decrease the temperature, first press and hold the  button for 2 seconds; and once you hear a beep sound, the set temperature on the digital temperature display will start flashing.
- Short press the  button to decrease the temperature or short press the  button to increase the temperature by 1°C at a time.
- The temperature range for the milk cooler is -1°C to 5°C.
- The display will show the desired set temperature and, once set, will indicate the current internal temperature of the appliance.
- To power the internal LED light on or off, short press the  button to turn the internal LED light on or off.

CLEANING THE APPLIANCE

To ensure safety, remember to always disconnect the appliance from the power supply before any form of maintenance or cleaning.

INTERNAL CLEANING

- Remove accessories from the appliance. Accessories can be cleaned separately with soap and water. Do not put them in the dishwasher.
- Do not use any abrasive materials or detergents.
- After washing, rinse with clean water and dry carefully.
- When you are done cleaning the appliance reconnect the plug with dry hands.

EXTERNAL CLEANING

- DO NOT POUR WATER OVER THE APPLIANCE.
 - Wash the exterior of the appliance with warm soapy water.
 - PLEASE DO NOT use abrasive materials or detergents.
 - Be careful of sharp edges under the appliance.
 - Once or twice a year, dust the compressor at the back with a brush or a vacuum cleaner, as over time it accumulates dust and that may affect the performance of the appliance and cause increased energy consumption.
 - Do not use any sharp objects for cleaning.
 - Do not wash the appliance with direct or high-pressure water jets.
-

FOOD STORAGE

- The appliance compartment is suitable for short-term storage of fresh food. The temperature inside varies depending on the amount of food stored.
 - To maintain good cooling efficiency and save energy, we recommend less frequent opening and closing of the appliance door.
 - Do NOT overload the fridge and ensure you keep enough space around items for cold air flow.
 - Do not block any ventilation openings.
-

ENERGY SAVING TIPS

- Place the appliance in the coolest area of the room, away from any heat-producing appliances and out of direct sunlight.
- Do NOT overload the appliance as the compressor will run longer.
- Do not set the thermostat on excessively cold temperatures.

TROUBLESHOOTING

Should you experience any issues with your appliance and the below troubleshooting tips do not resolve the fault experienced, kindly contact SnoMaster Service Department or your nearest accredited Service Agent:

PROBLEM	PROBLEM POSSIBLE CAUSE / MEASURE
Appliance is not turning on	<ul style="list-style-type: none"> • Check if the appliance is correctly switched on. • Check if there has not been loadshedding or a power cut. • Check if plug is not faulty or damaged. • Check if voltage is correct.
Temperature within the appliance is not getting cold enough	<ul style="list-style-type: none"> • Check that the appliance is not overloaded. • Check if appliance is not placed in direct sunlight. • Check if door is closed completely/ not frequently opening the appliance. • Check door gasket if not sealing properly and check for damages or tears on the gasket. • Check if the cooler does not have the correct clearances at the sides/back.
Temperature within the appliance is too cold	<ul style="list-style-type: none"> • Please relocate the appliance to a warmer area, preferably at room temperature. • Not enough ventilation around the unit. • Check if Thermostat probe is not faulty, if so please contact SnoMaster support to replace.
Moisture forms on the inside/ outside walls of the appliance	<ul style="list-style-type: none"> • Hot and humid weather usually in the coastal locations increases the internal rate of condensation. This is normal. • Set the temperature to a higher setting to avoid condensation. • Condensation may occur seasonally depending on humidity and ambient temperature. • Open the door less frequently and ensure it is closed properly at all times.
Exterior of appliance is wet	<p>Condensation will form on the outside of the appliance if it operates in humid areas or in the rainy season, simply wipe it dry with a non-abrasive cloth.</p>

TROUBLESHOOTING

PROBLEM	PROBLEM POSSIBLE CAUSE / MEASURE
Smell/Odour	<ul style="list-style-type: none"> • Check for spillages on each shelf/drawer. You may need to remove the shelves/drawers to check that no spillages have settled underneath them. • Double check if all foods and drinks in the appliance have not expired. If they have expired, then they should be removed immediately. • Placing charcoal in the appliance for a while can also help eliminate the smell/odour.
Door does not close properly	<ul style="list-style-type: none"> • Check if door gasket/seal is not torn or worn out. • Check if door compartments and shelves are correctly placed inside the appliance. • Check if the appliance is leveled. • Ensure there are no obstructions preventing the door closure.
Unusual noises/ Gurgling or Cracking Noises	<ul style="list-style-type: none"> • Ensure appliance is positioned level on the surface. • Caused by the flow of refrigerant when each cooling cycle ends. • Check if there is enough spacing around the appliance and ensure it is not touching other items. • This is normal, as the appliance makes a sound when the unit is expanding and contracting along its walls. • The pipes might be touching or some parts came lose, please contact a service agent.
Appliance door not opening	<ul style="list-style-type: none"> • If the door has just been opened, leave it for a minutes to allow air pressure to equalize before trying to open it again.
Exterior surface is warm	<ul style="list-style-type: none"> • This is normal while the compressor works to transfer heat from inside the appliance cabinet it can reach up 70-90°C.
Compressor runs for 1-5 mins/continuously	<ul style="list-style-type: none"> • The ambient temperature is too high, please relocate the appliance to a better ventilated or cooler place. • The voltage is incorrect, switch off the appliance and restart when the power has stabilised.

TROUBLESHOOTING

PROBLEM	PROBLEM POSSIBLE CAUSE / MEASURE
Compressor runs but the compartment is not getting cold	<ul style="list-style-type: none"> • The appliance has leaked or the system may be blocked please contact a service agent.
The digital display is not turning on	<ul style="list-style-type: none"> • Check that the appliance is correctly switched on. • Check that the plug is not damaged or faulty. • The Main control board is damaged or faulty and needs to be replaced.
LED display is very dim	<ul style="list-style-type: none"> • The external lighting may be too bright, making the display appear dim. Move the appliance to a low-lit area. • The Display may be faulty / the control board is damaged or faulty and needs to be replaced.
The digital display buttons are not functional	<ul style="list-style-type: none"> • The temperature controller panel is damaged.
The interior LED light does not switch on	<ul style="list-style-type: none"> • The LED light needs to be replaced. • The Main control board is faulty or damaged. • The light panel is faulty or damaged.



ICE COLD ANYWHERE

**JOHANNESBURG LIFESTYLE
CENTRE & SERVICE CENTRE**

49 Koornhof Road
Meadowdale
Germiston, 1614
011 392 5315 / 3147
info@snomaster.co.za

**CAPE TOWN LIFESTYLE CENTRE
& SERVICE CENTRE**

31 Stella Road
Montague Gardens
Cape Town, 7441
021 100 5695
info@snomaster.co.za

snomaster.co.za



@SnoMasterSA



SnoMaster SA



snomaster_south_africa



@SnoMaster