

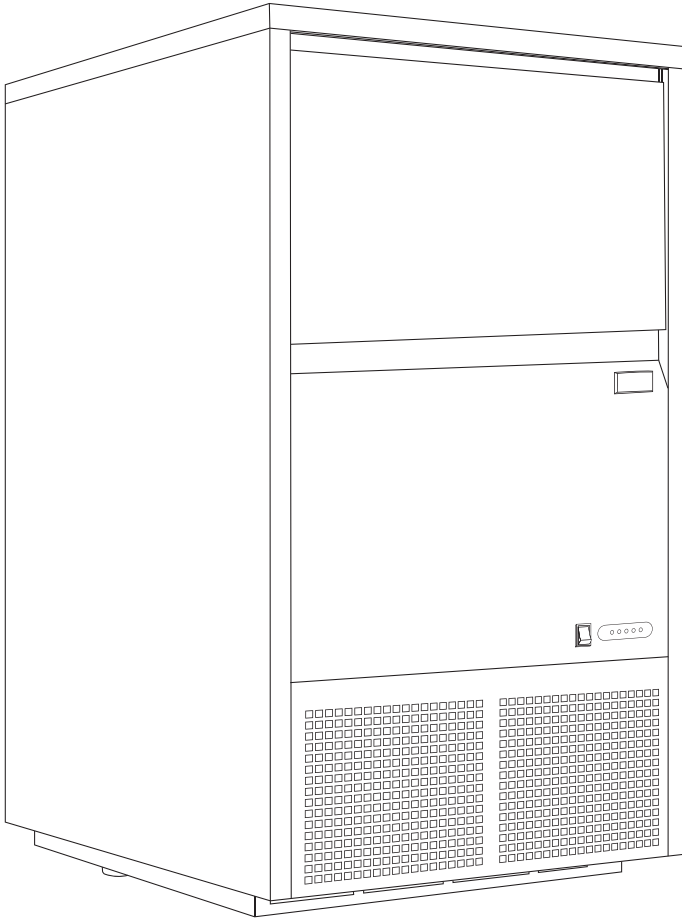

USER MANUAL AND PRODUCT SPECIFICATIONS

ICE COLD ANYWHERE



SM-80

**80KG PLUMBED-IN
ICE-MAKER**

CONTENTS

WARRANTY, SERVICE AND SUPPORT	01
Warranty Registration	
Service and Support	
IMPORTANT SAFETY INFORMATION	02
Before Using Your Appliance	
Critical Safety Information For Your Safety	
PRODUCT FEATURES	04
INSTALLATION INSTRUCTIONS	05
Accessories Included	
Structure	
Operation Procedure	
Control Panel	
MAINTENANCE	11
Cleaning the Interior	
Cleaning the Exterior	
ENERGY SAVING TIPS	12
TROUBLESHOOTING	13
SM-80 LIST OF PARTS	14



THANK YOU FOR PURCHASING THE SM-80, 80KG PLUMBED-IN ICE-MAKER

• WARRANTY, SERVICE AND SUPPORT •

This product is warranted for **1-year on the compressor, 1-year on the unit and 1-year on all parts not listed from the date of purchase**. Warranty does not cover products that have not been used in accordance with the user guide or are outside the warranty terms and conditions, which can be found at the following url:

<https://snomaster.co.za/warranty/>

WARRANTY REGISTRATION

Register your SnoMaster SM-80, 80Kg Plumbed-In Ice-Maker now for warranty, and allow us to provide you with the best possible after sales service:

- Please log onto our website at **www.snomaster.co.za**
- Click on the 'Warranty' tab.
- Enter warranty information and upload proof of purchase at the bottom of the page.

SERVICE AND SUPPORT

Should an instance arise where you require assistance, contact our service team:

- Please log onto our website at **www.snomaster.co.za**
- Click on the 'Support' tab.
- Click 'Find a Repair Agent Near You' and enter your region.
- Alternatively contact us via email: **info@snomaster.co.za** or contact us on **+27 11 392 5315**.

IMPORTANT SAFETY INFORMATION

SM-80, 80KG PLUMBED-IN ICE-MAKER

This manual contains important information including safety, installation, maintenance and warranty instructions of the SnoMaster SM-80, 80kg Plumbed-In Ice-Maker. Please read this manual carefully before use and follow all safety information and instructions. It is recommended to keep this manual for easy reference so that you are familiar with the operation and maintenance of your appliance.

CRITICAL SAFETY INFORMATION FOR YOUR SAFETY

Before using this appliance, ensure it is correctly positioned and installed as outlined in this manual. Follow these basic precautions to prevent the risk of fire, electrical shock, or injury:

- This appliance is designed for domestic indoor use only and is exclusively intended for making ice.
- Ensure that the incline angle of the appliance is not more than 45° during transportation or operation.
- Before using your appliance for the first time, you should wait about 12 hours after positioning it in a place.
- Ensure sufficient personnel are available to move and install the appliance to prevent damage or injuries.
- Installation of this appliance by a certified plumber is recommended.
- The appliance needs to be levelled for optimal operation. You can adjust the appliance feet to level it +/-150mm.
- For optimal drainage, ensure that the drain outlet is positioned at least 100 millimeters below the ice maker's drainage tube outlet. This arrangement facilitates efficient water outflow by utilizing gravitational force.
- Ensure the plug is easily accessible after positioning the appliance.
- Avoid connecting or disconnecting the electric plug with wet hands.
- To disconnect the appliance, grip the plug and pull it from the wall outlet. Never pull out the plug by the cord.
- It is advisable to use a dedicated power source and avoid using extension cords.

- Please unplug the appliance or disconnect the power before performing any cleaning, maintenance, or servicing.
 - If the appliance power supply cord is damaged, it must be replaced by SnoMaster, its approved agent, or a similarly qualified person to prevent any hazard.
 - It is recommended that the circuit breaker size should be no more than 20 amps.
 - This appliance operates on a single-phase voltage of 230V/50Hz, to avoid electrical surges, it is advised to use a surge protector plug.
 - Cleaning and maintenance should be supervised by adults, especially if children are involved.
 - The appliance should be placed on a flat surface and should be completely unobstructed. Ensure to leave 150mm space around the appliance to ensure proper ventilation for the appliance. Place the appliance away from direct sunlight and heat sources (stove, heater, radiator, etc.).
 - Unless specifically recommended in this manual, do not attempt to repair or replace any part of the appliance. All other servicing should be referred to a qualified technician.
 - Never clean appliance parts with flammable fluids as they may create a fire hazard or explosion. Also, avoid storing or using petroleum or other flammable vapours and liquids near this appliance.
 - Avoid solvent-based cleaning detergents or abrasives on the interior or exterior as they may damage or discolour it.
-

BEFORE USING YOUR APPLIANCE

- Ensure all packaging materials, stickers and films are removed from the product. Clean the appliance's surfaces with a mild detergent and a damp cloth before initial use.
- Before connecting the appliance to a dedicated power source, let it stand upright for approximately 12 hours. This measure helps minimise the risk of cooling-system malfunctions that might occur due to handling during incorrect transportation.
- Ensure all electrical connections are clean and dry before switching on the appliance.
- Ensure all parts are correctly assembled before operation.



WARNING: RISK OF FIRE/ FLAMMABLE MATERIALS

This appliance contains R290a refrigerant, which is FLAMMABLE and may cause a fire or an explosion.

- Do not store explosive substances such as aerosol cans with a flammable propellant in this appliance.
 - Do not damage the refrigerant circuit.
 - Do not use electrical appliances inside the storage compartments of the appliance, unless they are of the type recommended by the manufacturer.
-



WHEN DISPOSING OF THE APPLIANCE

Please observe the following instructions:

- Always ensure the appliance is out of reach of children. Before disposing of it, damage the body to prevent children from climbing inside, ensuring their safety.
 - Follow the instructions of your local regulations when disposing.
-

PRODUCT FEATURES

60 CUBES PER CYCLE | GOURMET ICE | ICE SIZE (MM): (H) 34 (D) 28.5 | REFRIGERANT: R290

SPECIFICATIONS:

- **Dimensions (mm) Unit:** (H) 1140 (W) 730 (D) 620
- **Storage Bin Volume:** 45Kg
- **Adjustable Feet (mm):** +/- 150mm
- **Net Weight:** 74Kg
- **Ice Making Capacity:** 80Kg/24h
- **Voltage:** 220-240V/50Hz
- **Total Input Power:** 665W

- **Dimensions (mm) Packaged:** (H) 1140 (W) 730 (D) 620
 - **Rated Current:** 3.5A
 - **Suggested Applications:** Office, Commercial Operation, Canteen, Sports Bar, Hotel, Café, Gym
 - **Design Criteria:** Engineered for the African Climate
-

**WATER INLET ~ WATER FILLING ~ ICE MAKING
~ WATER RELEASING ~ ICE DROPPING**

All these processes are automatically controlled for continuous ice-making.

Should the water supply deplete or the ice storage bin reach capacity, the operational panel's indicator light will activate, and the ice-maker will cease operation automatically. The insulated design of the ice storage bin serves to maintain the ice in a solid state for an extended period.

INSTALLATION INSTRUCTIONS



Before installing your new appliance, please read all safety instructions in this manual and follow the installation instructions below:

WATER

- Water treated with reverse osmosis purification often gives a false water indicator, it is advised to fit an inline mineral filter for the sensors to detect the water.
- Ice cycle time is dependent on water temperature. Clean and drain the appliance at least one or twice a month. Lemon juice or 10ml vinegar can be added to the water to help the cleaning process.
- To prevent lime build-up it is advised to clean the appliance with a descaling liquid once a month, dependent on the water quality in your area.

ACCESSORIES INCLUDED

Please Check If All The Accessories Shown Below Are Included:

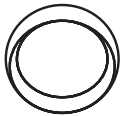

2 x O RINGS TO SEAL THE WATER INLET/ OUTLET PIPES



1 x ICE SCOOP



1 X FILTER HOUSING BRACKET



4 x SCREWS FOR FILTER CASING BRACKET

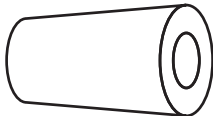

1 x FILTER CARTRIDGE

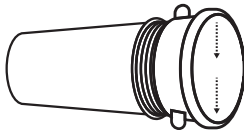

1 x FILTER CARTRIDGE HOUSING

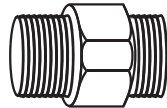

2 x WATER INLET / OUTLET FITTINGS

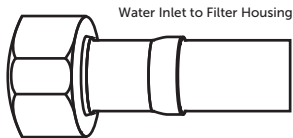

1 x LONG WATER INLET

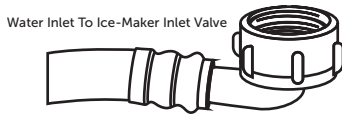
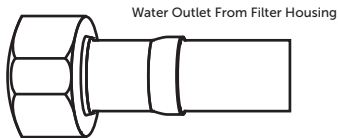

1 x SHORT WATER INLET

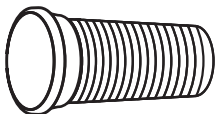

1 x DRAIN OUTLET PIPE



2 x SEAL RINGS FOR FILTER CARTRIDGE WATER INLET AND OUTLET

STRUCTURE

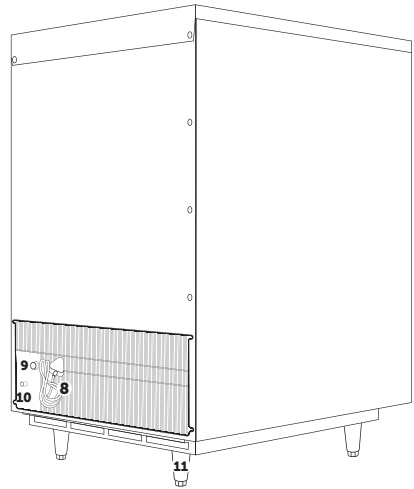
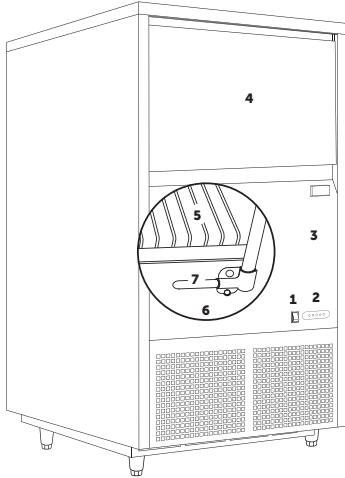

- 1** Power Switch
- 2** Display Panel
- 3** Front Panel
- 4** Door
- 5** Ice Grid
- 6** 45kg Ice Storage Bin

- 7** Ice Full Sensor
- 8** Power Cord
- 9** Water Inlet Valve
- 10** Drainage Outlet
- 11** Leveling Feet

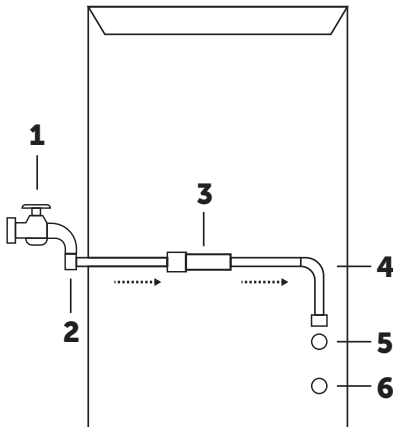

INSTALL THE WATER INLET SYSTEM AS FOLLOWS:

- 1** Tap
- 2** Water Filter Inlet Pipe
- 3** Water Filter
- 4** Water Filter Outlet Pipe
- 5** Water Inlet Valve
- 6** Drain Outlet

(Drain Outlet Must Be 100mm Lower Than The Appliance)

*Arrows Indicate Direction Of Water Flow

SURGE PROTECTOR PLUG

To protect the appliance from electrical surges, it is advised to use a surge protector plug.

(Please note that this must be purchased separately and is not supplied with the appliance.)

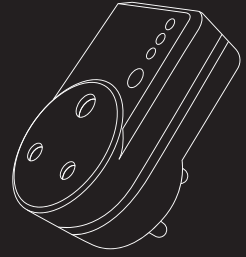

OPERATION PROCEDURE

Installation of this appliance by a certified plumber is recommended

- Remove the appliance from the box and all accessories.
- Ensure the appliance is placed on a level floor for quieter operation.
- Beware that placing the appliance on a carpet may cause the heat from the compressor to cause the carpet to fade.
- To maximize the ice-making performance of our plumbed-in ice-makers, it's ideal to have them in a steady environment with a 20°C ambient temperature and 10°C water temperature. While our ice-makers can handle higher temperatures, these conditions ensure peak production capacity.
- Avoid areas where the appliance might be exposed to direct sunlight, any sources of heat (stove, heater, radiator, etc.), extreme hot ambient temperatures or excessive moisture.
- Place the ice bin protector at the bottom of the ice bin and make sure the drainage hole is not blocked, so the water can drain smoothly.
- Attach one end of the water inlet pipe to the water inlet valve on the back of the appliance. When connecting this pipe, use the sealing washers supplied with the ice-maker to eliminate the risk of a water leak. The other end of the pipe should be connected to one of the filter housing connectors.
- Connect the other water inlet pipe to the other side of the filter housing connector. Connect the other end to a dedicated water supply or tap. When connecting this water inlet, use the sealing washers supplied to eliminate the risk of a water leak.

- Remove the protective plastic film from the filter cartridge prior to installation. Carefully align the cartridge within the filter housing, ensuring it is seated evenly within the designated grooves. Secure the housing lid by screwing it on gently to avoid compromising the integrity of the filter.
- The drain outlet pipe must be fitted to the drain outlet fitting on the ice-maker. Use a cable tie to secure it once fitted to prevent leakage.
- This appliance utilizes a gravity-fed drainage system. Therefore, the drainage outlet pipe must be positioned a minimum of 100mm below the level of the appliance's drain pipe hole, ensuring a downward trajectory for effective water flow.
- The water pressure must be between 2 and 4 bar.
- Plug the power cord into a dedicated power source, then press the on/off switch to start the ice-making process. The green "run" light will be lit, and the ice-maker will start to operate.
- The operation of the ice-maker is completely automatic.
- If the storage container is full with ice, the "ice full" indicator on the display panel will be lit up, and the ice-maker will stop automatically.
- Remove the ice from the storage container and then the ice-maker will restart automatically after a short while.
- Should the water supply to the appliance be insufficient, the "water low" light indicator will light up. The ice-maker will stop automatically.
- When the water supply is restored, the ice-maker will restart automatically again after a short while.

CONTROL PANEL

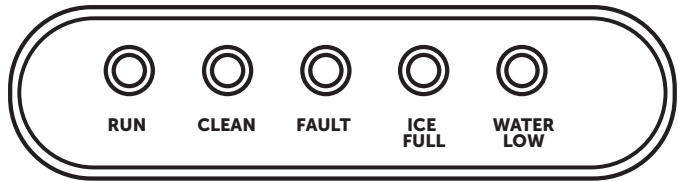
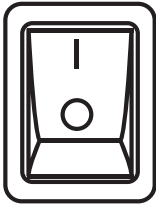

- Use the On/Off switch to power the appliance on or off. The On/Off switch light will indicate the appliance is on.
- Let the appliance run a few cycles so that it can fully calibrate.
- The appliance will now start making ice. *Time between ice making cycles will vary depending on the ambient and water temperature.

SWITCHING THE APPLIANCE OFF:

- Wait for the current ice cycle to finish and use the On/Off switch to turn the appliance off.
- Unplug the appliance from the power source.

MAINTAINENCE

To ensure safety, remember to always disconnect the appliance from the power supply before any form of maintenance or cleaning.

CLEANING

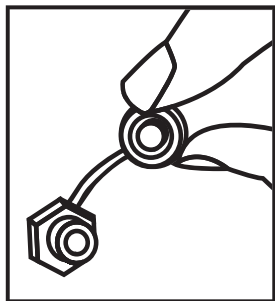

INTERNAL CLEANING

- Remove the drain cap.
- Remove the grommet for the water to drain.
- Refit the grommet and the drain cap after the water reservoir has drained completely.
- Ensure that the water inlet filter does not have any debris
- Wipe the interior dry and use a damp cloth with warm water and a mild detergent.

AVOID USING ANY HARSH CHEMICALS.

- Replace the filter cartridge periodically, depending on usage and water quality.
- Clean the ice full sensor regularly.
- For extended periods where the appliance will not be in use, ensure that the interior is completely dry, the water reservoir is completely drained.

CLEANING THE SPRAY WATER SYSTEM

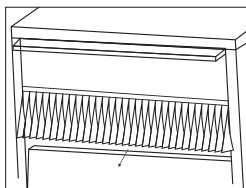

STEP 1

- Remove the block water board.
- Pull out the ice flopping shelf.

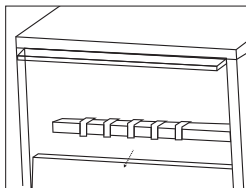

STEP 2

Take off the spray pipe connection (The silicone tube) then take out the spray pipe.

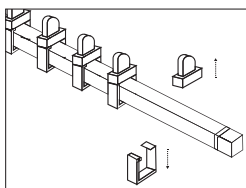

STEP 3

- Remove the spray nozzles and the nozzle clamps as illustrated, one by one.
- Wash the spray pipe and the nozzles with a soft brush.

External Cleaning

- Dust the compressor at the back of the appliance with a brush or vacuum cleaner periodically, as dust build-up may affect the performance of the appliance.
- Avoid using sharp objects, high-pressure water jets or abrasive materials when cleaning the appliance.
- It is advisable to use a silicon based stainless steel polish cleaner to clean the exterior of the appliance.

ENERGY SAVING TIPS

Place the appliance in the coolest area of the room, away from any heat-producing appliances and out of direct sunlight.

TROUBLESHOOTING

Should you experience any issues with your appliance and the below troubleshooting tips do not resolve the fault experienced, kindly contact SnoMaster Service Department or your nearest accredited Service Agent:

PROBLEM	PROBLEM POSSIBLE CAUSE / MEASURE
The ice-maker does not switch on	<ul style="list-style-type: none">• Check if the ice-maker is correctly switched on.• Check if there has not been loadshedding or a power cut.• Make sure you have followed the installation requirements correctly.
Water shortage indicator light is on	<ul style="list-style-type: none">• Check the water supply and if the inlet pipes are pinched or the water filter is blocked, if there are no obstructions restart the ice-maker.• Check if the water pressure is between 2 and 4 bar pressure.• Check if the water box nut is loose and tighten accordingly.• The water solenoid valve could be faulty.• The water level sensor is dirty and will need to be cleaned or replaced.

TROUBLESHOOTING

PROBLEM	PROBLEM POSSIBLE CAUSE / MEASURE
Compressor doesn't work	<ul style="list-style-type: none"> • Check if the condenser fan is working. • Remove some ice. Ice full light might be on. • The compressor is faulty.
Compressor works, but no ice is being made	<ul style="list-style-type: none"> • The refrigerant has leaked and will need to be re-gassed. • The gas solenoid valve will need to be replaced. • The appliance has a blockage and will need to be flushed and re-gassed. • Check if the condenser fan is working.
Ice is not dropping or struggling to drop	<ul style="list-style-type: none"> • Check if the ambient temperature is too low (lower than 10°C) or water temperature is too low (lower than 7°C) • Replace the gas solenoid valve. • The water/evaporator sensor is faulty. • The circulation pump is faulty and the ice is getting stuck together and not releasing.
Fault indicator lights on	<ul style="list-style-type: none"> • The water box nut might be loose and must be tightened. • The water box motor is faulty. • The water/evaporator sensor or 'ice full' sensor must be replaced. • The water inlet valve is faulty. • The pc board is faulty.

SM-80 LIST OF PARTS

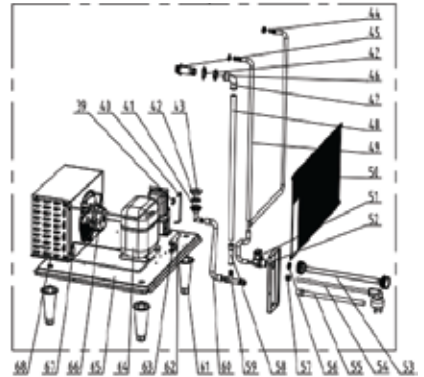
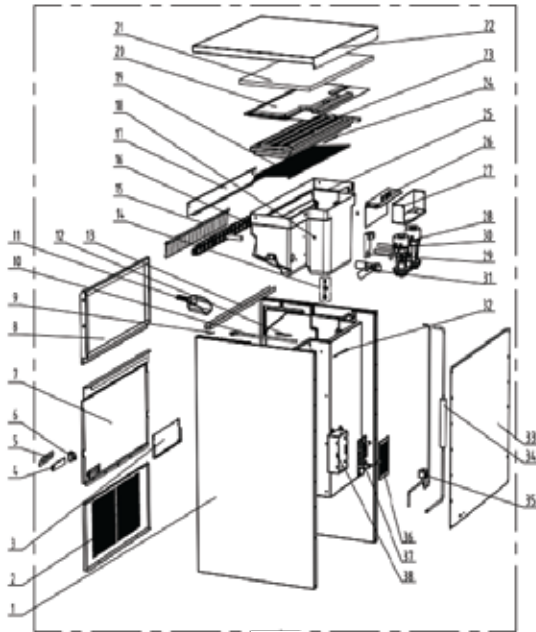

- | | | | |
|----|--------------------------------|----|----------------------------------|
| 1 | Inner Liner | 36 | Control Box Cover |
| 2 | Ventilation Panel | 38 | Control Box |
| 3 | Down Panel Fixer Board | 37 | Main Control Board |
| 4 | Operation Panel | 39 | T Tube |
| 5 | Sticker Of Operation Panel | 40 | Discharge Tube |
| 6 | Power Switch | 41 | Drainage Connector |
| 7 | Down Panel | 42 | Pad |
| 8 | Door | 43 | Drainage Pipe Warp |
| 9 | Snap-gauge For Side Panel | 44 | Drainage Pipe Screw Net |
| 10 | Ice Full Level Sensor Fix Tube | 45 | Water Recycle Tube Connector |
| 11 | Ice Scoop | 46 | Water Recycle Tube Screw Nut |
| 12 | Ice Full Level Sensor | 47 | Elbow Pipe |
| 13 | Fix Board For Side Panel | 48 | Water Recycle Tube |
| 14 | Water Drainage Valve | 49 | Water Refill Pipe Assembly |
| 15 | Water Curtain Hinge | 50 | Back Grill |
| 16 | Spray Tube | 51 | Water Inlet Valve |
| 17 | Water Curtain | 52 | Water Valve Fix Board |
| 18 | T Block | 54 | Power Cord |
| 19 | Ice Shove | 55 | Drainage Pipe |
| 20 | Evaporator Cover | 56 | Seal Washer For Water Inlet Pipe |
| 21 | Top Insulation | 57 | Power Cord Buckle |
| 22 | Top Panel | 58 | Water Recycle Tube |
| 23 | Evaporator | 59 | Water Drainage Connector |
| 24 | Evaporator Sensor | 60 | Water Drainage Tube |
| 25 | Water Box | 61 | Feet |
| 26 | Water Pump Accessory | 62 | Drier Filter |
| 30 | Spray Tube Connector | 63 | Support For Filter |
| 32 | Ambient Temp. Sensor | 64 | Compressor |
| 33 | Back Panel | 65 | Compressor Fixer Board |
| 34 | Suction Tube | 66 | Fan |
| 35 | Magnetic Valve | 67 | Condenser Sensor |
| | | 68 | Condenser |



ICE COLD ANYWHERE

**JOHANNESBURG LIFESTYLE
CENTRE & SERVICE CENTRE**

49 Koornhof Road
Meadowdale
Germiston, 1614
011 392 5315 / 3147
info@snomaster.co.za

**CAPE TOWN LIFESTYLE CENTRE
& SERVICE CENTRE**

31 Stella Road
Montague Gardens
Cape Town, 7441
021 100 5695
info@snomaster.co.za

snomaster.co.za



@SnoMasterSA



SnoMaster SA



snomaster_south_africa



@SnoMaster